

SEE 806830B FOR BASE ELECTRICAL SCHEMATIC

WIRE PLC OUTPUTS FOR ROLLER DECK FUNCTIONS 'ROLLOVER', 'EXTRACTOR ARM', AND 'ROLLER DECK' THROUGH SECOND SET OF NORMALLY OPEN CONTACTS ON OPERATOR SWITCHES 'SS35', 'SS33', 'SS37', 'SS39'

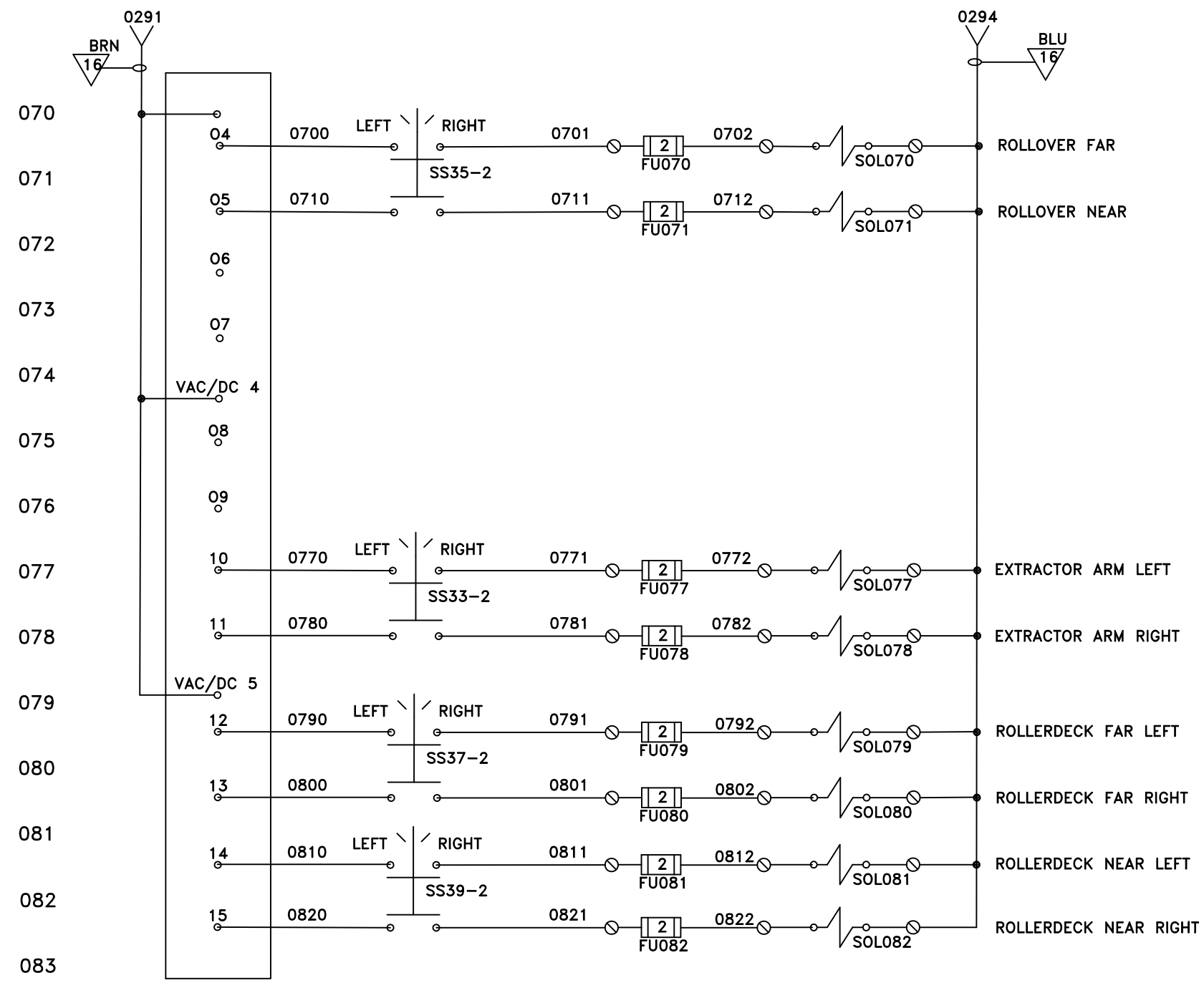

| - | MM/DD/YY | WHO | SEE REVISION SHEET |
|---|-----------|-----|---------------------------------|
| SYM | DATE | BY | DESCRIPTION |
| SACKETT MATERIAL HANDLING SYSTEMS INC. 1033 Bryn Mawr Ave. Bensenville, Illinois 60106-1244 | | | |
| SCALE: | APPROVED: | | DRAWN BY: PRE |
| DATE: | 05-10-10 | | REVISED: |
| HHA ELECTRICAL SYSTEM, REDUNDANT ROLLER DECK CONTACTS | | | ACAD CODE: |
| PAGE 1 OF 1 | | | DRAWING NUMBER: 806830B-RRDC |